

HYDRASONIC I-UWM Ultrasonic Water Meter (Flanged)



Attention:

- Installation should only be carried out by qualified, trained personnel.
- Violation and removal of the manufacturer's seals is not allowed, otherwise the warranties are void.
- Welding on pipes near the meter is prohibited. The device must be dismantled before welding.
- Eliminate the possibility of flooding the electronic unit.
- The ambient temperature should be between 0 °C and 55 °C.

Table of content

1. General Information	1
1.1 Application and Function	1
1.2 Contents of the package	1
1.3 Standards	1
2. Installation procedure	2
2.1 Installation of the meter	2
2.2 Installation angle	3
2.3 Straight inlet	4
3. Installation procedure	4
4. Lay length of water meter	5
5. Display Menu	6
5.1 Main Display	7

1. General Information

1.1 Application and Function

The Hydrasonic i-UWM is designed for the measurement of cold water flow in a water supply system.

1.2 Contents of the package

- Water meter, consisting of a calculator, and a flow sensor, all permanently connected
- Installation kit (depending on type)
- Installation and Operating Instructions
- Operating Instructions, Communication Interfaces S3(C) (with meters with an optional interface)
- Declaration of Conformity

1.3 Standards

- This product fulfills the requirements of the European Council Directive on Electromagnetic Compatibility (EMC Directive) 2014/30/EU.
- The identification plate of the instrument and the seals must not be removed or damaged otherwise the guarantee and the approved application of the instrument are no longer valid!
- To achieve measurement stability of the meter it is necessary that the water quality meets the requirements of the AGFW-recommendation FW-510 and the document VDI (Association of Engineers) VDI 2035.
- The water meter left the factory in conformance with all applicable safety regulations. All maintenance and repair work are to be carried out only by qualified and authorized technical personnel.
- Instruments with activated radio function are not allowed on air freight.
- The correct installation point in the system must be chosen: inlet or outlet flow.
- To clean the water meter (only if necessary) use a slightly moist cloth.
- To protect against damage and dirt the water meter should only be removed from the packaging directly before installation.
- If more than one water meter is installed in one unit, care must be taken to ensure that all meter shave the same installation conditions.
- All specifications and instructions listed on the data sheet and in the application notes must be adhered to, further information can be obtained at **www.kimans.com**
- The water meter has a lithium-metal-battery. Do not open the batteries, do not bring the batteries into contact with water or expose them to temperatures above 80 °C. Do not charge them or short-circuit them.
- Instruments that have been replaced or exchanged must be disposed of according to relevant environmental regulations.

2. Installation procedure

2.1 Installation of the meter



Ensure the meters are NOT installed during flushing (RISK OF DAMAGE!)

- Check section 4 for meter lay length.
- Install a spool piece at the installation location that is equal to or larger than the meter lay length determined.
- Flush the pipes professionally, taking care not to damage any system components.
- Close the isolation valves at the installation location.
- Open the nearest draining valve for pressure release.
- Drain the spool piece pipe section.
- Use gaskets between mating flanges on the pipe and meter.
- The meter can be installed in supply or return flow lines. During installation, pay attention to the flow direction of the medium is the same as the arrow on the water meter pipe body.

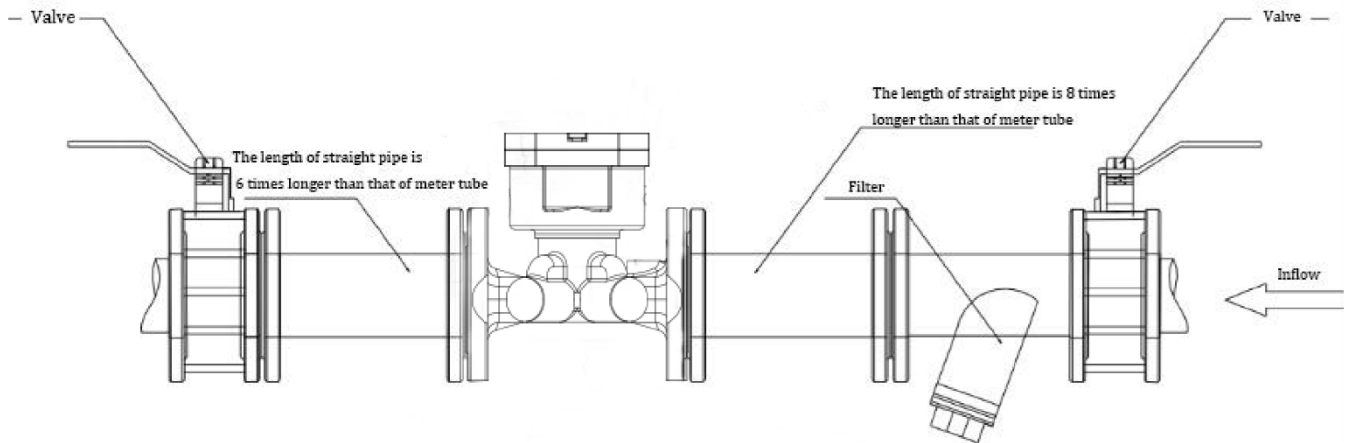

- It is recommended to install a filter before the inlet of the meter, and to be cleaned and maintained regularly.

2.2 Installation angle

The meter can be installed horizontally, vertically, or at an angle.

The meter is normally installed horizontally, the lifting rings being vertically oriented. The ultrasound paths in the flow sensor tube will thus be vertical, which is optimal in connection with the possible stratification of the medium.

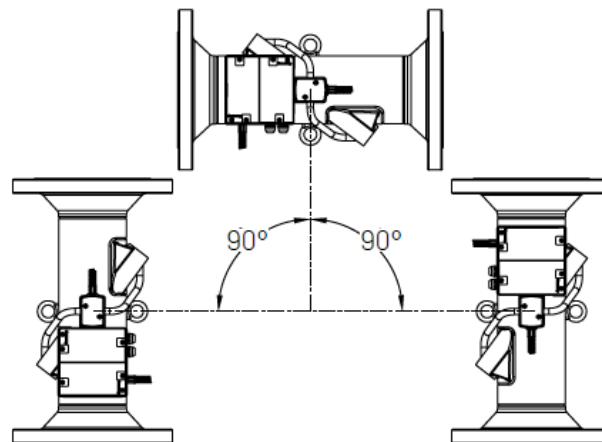

2.3 Straight inlet

Optimal position can be obtained by taking the below-mentioned installation methods into consideration.

- A. Recommended meter position.
- B. Recommended meter position.
- C. Unacceptable position due to risk of air build-up.
- D. Acceptable position in closed systems. Unacceptable position in open systems due to risk of air build-up in the system.
- E. Meter not to be placed immediately after a valve, with the exception of isolation valves which must be fully open when it's not used for blocking.
- F. Meter not to be placed directly before (inlet side) or directly after (outlet side) of a pump.
- G. Meter not to be placed directly after a double bend, in two levels.

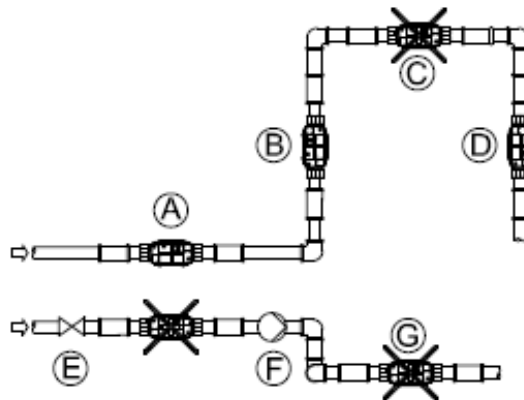

3. Installation procedure

The meter can be put into operation once it has been installed.

Proceed as follows:

- After the installation of the water meter, open the isolation valves, and allow the water to pass inside the meter.
- Check the system for leaks.
- Check the display for flow rate.
- Seal the sensors.
- Attach the seals to the calculator and temperature sensors.
- Read the meter counts for volume, and operating hours.
- Ensure no errors are displayed on the LCD

4. Lay length of water meter

Diameter	Length (L)	Height (mm)	Width (mm)	Stud Bolt	Bolt holes
DN50	200	223	165	M16	4
DN65	200	231.5	175	M16	4
DN80	225	249	184	M16	8
DN100	250	257.5	205	M16	8
DN125	250	280.5	230	M16	8
DN150	300	308	260	M20	8
DN200	350	331	320	M20	12

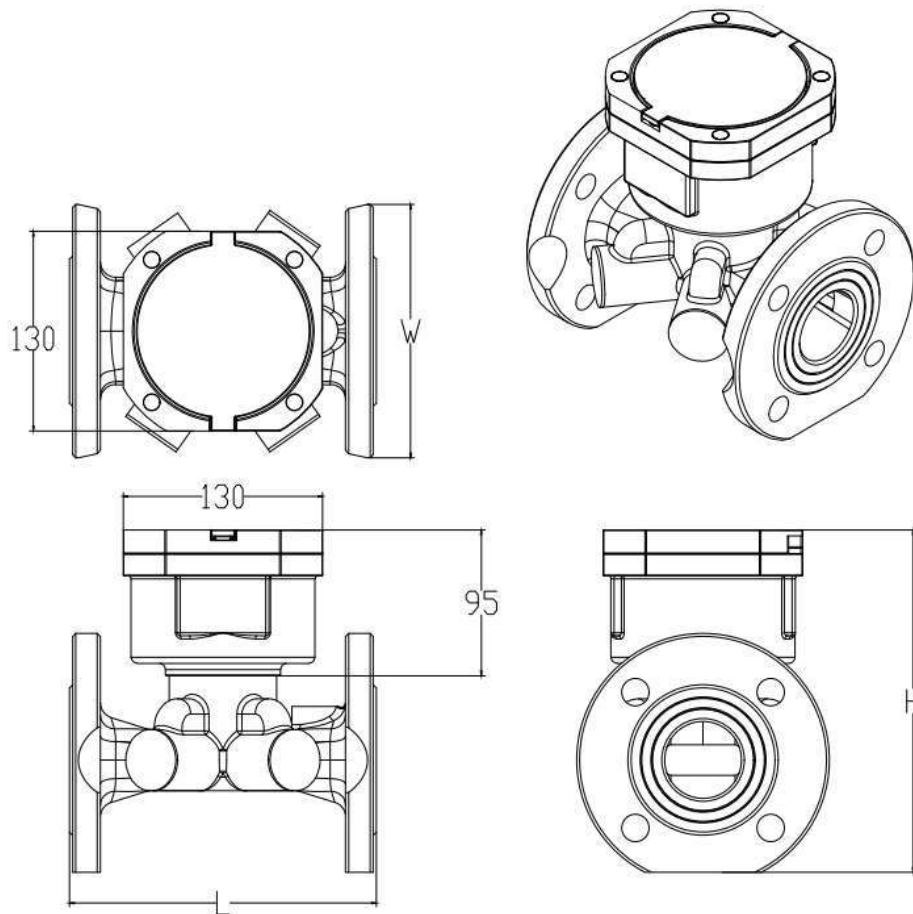

5. Display Menu

The calculator has a liquid crystal display with 8 digits and special characters. The values that can be shown are divided into five display loops. All data is retrieved using the push button next to the display.

At the start, you are automatically in the main loop (1st level).

By pressing the push-button longer than 4 seconds you change to the next display loop. Keep the push-button pressed until you reach the desired information loop.

By pressing the push button briefly each time you can scan all the information within a loop. After 2 minutes of non-use of the push-button, the display will automatically be deactivated.

[Ref. next page]

5.1 Main Display

