

HYDRASONIC F8

ULTRASONIC HEATING/COOLING BTU METER



FEATURES

- ▶ M-Bus or Wireless M-Bus (OMS radio 868 MHz) communication. Enhanced transmission performance is achieved when combined with Diehl Metering AMR system technology
- ▶ Heat-transfer fluid: water
- ▶ Constant high measuring rates of the temperatures and volume with up to 12 years battery life time
- ▶ 8-digit LCD
- ▶ Removable calculator (0.45m coaxial cable) ensuring comfortable reading

HYDRASONIC F8

ULTRASONIC HEATING/COOLING BTU METER

GENERAL

HYDRASONIC F8 compact	
Application	Heating or bifunctional (heating /cooling) Heat-transfer fluid: glycol-free water
Approval	MID (DE-13-MI004-PTB008)
Accuracy class	Class 2
Ambient temperature	°C +5 ... +55 (<35 has a positive effect on battery lifetime)
Storage temperature	°C +5 ... +55 max. -20 ... +60 (max. 4 weeks)
Humidity	% 93 maximum
Battery supply	3.6 VDC 2xAA-Cell
Lithium content	g 2 x 0.7
Temperature sensor type	Pt 500, 2-wires: Ø 5.2 mm
Cable length of temperature sensor	m 1.45
Test possibilities	Via display
Volume measuring cycle	s 2
Temperature measuring cycle	s 16 (long radio telegram + Mbus) / 32 (short radio telegram)
Power calculation cycle	s 2

FLOW SENSOR - BASIC FEATURES

HYDRASONIC F8 compact	
Dynamic range (q_p/q_i)	1:100
Mounting position flow sensor	Any position, calming section not necessary
Temperature range (heating)	°C +5 ... +105*
Temperature range (heating/cooling)	°C +5 ... +105
Protection class	IP54 (heating) - IP68 (heating/cooling)

* +130°C in option

CALCULATOR - BASIC FEATURES

HYDRASONIC F8 compact	
Protection class	IP 65
Environmental class - mechanical	M1, M2
Environmental class - electromechanical	E1, E2
Calculator	Removable, with 0.45 m cable to flow sensor
Absolute temperature range	Θ °C +1 ... +105 (+130 in option)
Starting temperature difference	$\Delta\Theta$ K 0.125
Min. temperature difference	$\Delta\Theta_{\min}$ K 3 (MID approved)
Max. temperature difference (heating)	$\Delta\Theta_{\max}$ K 127 (MID approved)
Extensive readable data memory	2 predefined history logs for 720 daily (Log-1) and 120 monthly (Log-2) values of energy, volume and error hours; additionally event memory (error log)

INTERFACES

HYDRASONIC F8 compact	
Optical	ZVEI interface, for communication and testing, M-Bus protocol
Display	LCD, 8-digit
M-Bus	According to EN13757-3:2013
Wireless M-Bus	According to EN13757-4:2013

HYDRASONIC F8

ULTRASONIC HEATING/COOLING BTU METER

DISPLAY

HYDRASONIC F8 compact	
Display indication	LCD, 8-digit
Units	kWh - m ³ - °C - m ³ /h *
Total values	99,999.999
Values displayed (main loop)	Energy - Volume - Flow - Power - Temperature - Differential temperature - Operating days - Error Status - Display test

* MWh - GJ in option

M-BUS

HYDRASONIC F8 compact	
M-Bus	Auto baud detect (300 and 2,400 bauds); galvanically insulated
Data transmission	Data reading via 2 non-polarized wires (1.45 m)
Battery lifetime	Up to 12 years*

*Under standard conditions of use and temperature. Theoretical lifetime, with no guarantee.

WIRELESS M-BUS (RADIO)

HYDRASONIC F8 compact	
Frequency band	868 MHz
Type of radio telegram	Open Metering Standard (OMS)
Transmission data updating	Online - no time delay between value measurement and data transmission
Data transmission	Unidirectional
Battery lifetime	Up to 12 years*
Sending interval options ¹	Short telegram: 33 sec. for heating, 43 sec. for heating/cooling Long telegram: 64 sec. for heating, 91 sec. for heating/cooling

*Under standard conditions of use and temperature. Theoretical lifetime with no guarantee.

¹Factory settings

TECHNICAL DATA FLOW SENSOR

Nominal flow rate	q _p	m ³ /h	1.5	2.5
Nominal diameter	DN	mm	15	20
Overall length	L	mm	110	130
Starting flow rate		l/h	2.5	4
Minimum flow rate	q _i	l/h	15	25
Maximum flow rate	q _s	m ³ /h	3	5
Overload flow rate		m ³ /h	4.6	6.7
Operating pressure	PN	bar	16	16
Kvs value ($\Delta p = Q^2 / Kvs^2$)			4.33	7.91
Pressure loss at q _p	Δp	mbar	120	100

HYDRASONIC F8

ULTRASONIC HEATING/COOLING BTU METER

DIMENSIONS THREAD VERSION

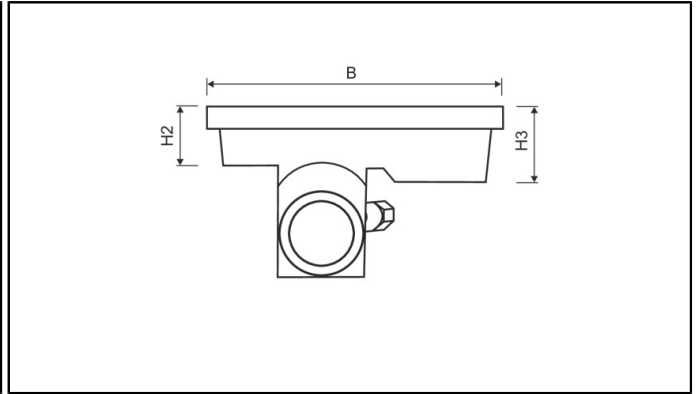
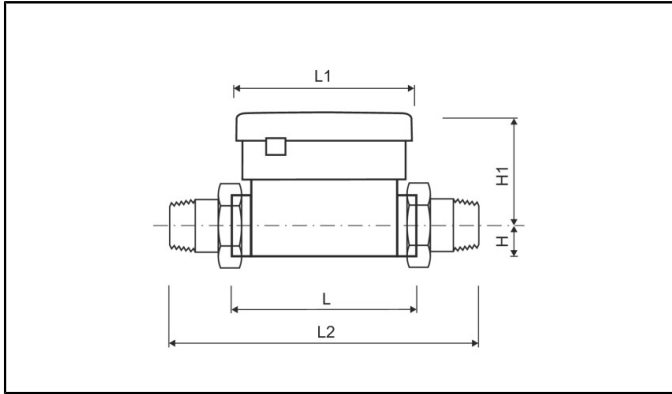

Nominal flow rate	q_p	m ³ /h	1.5	2.5
Nominal diameter	DN	mm	15	20
Overall length	L	mm	110	130
Overall length with coupling	L2	mm	190	230
Length of calculator	L1	mm	90	90
Height	H	mm	14.5	18
Height	H1	mm	55	58
Height of calculator	H2	mm	27	27
Height of calculator	H3	mm	40	40
Width of calculator	B	mm	135	135
Connection thread on meter		inch	G $\frac{3}{4}$ B	G1B
Connection thread of coupling		inch	R $\frac{1}{2}$	R $\frac{3}{4}$
Weight		kg	0.70	0.77

PRESSURE LOSS GRAPH / TYPICAL ERROR GRAPH

